

# Active Ventilation Products, Inc.

Visit us: [roofvents.com](http://roofvents.com)

Email us: [sales@roofvents.com](mailto:sales@roofvents.com)

# Installation Instructions

3/7/2024

Boot Vent Kit Models: FL-11.8125-C12 & Boot-TPO-12-C12 Head Diameter: 12"

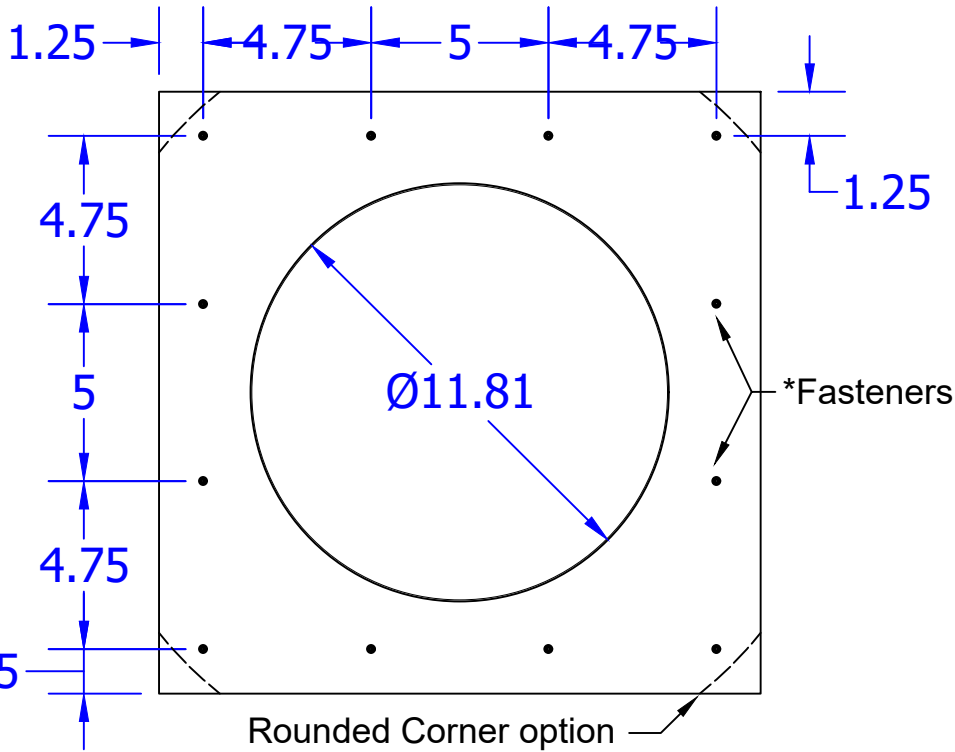

### Step 1: Cut out hole to flange diameter.

Pull back boot, and install sub-base using Flat, Bugle or Wafer Head #10 x 1 1/2" Sheet Metal Screws, Type A Point [Quantity: 12]

### Step 2: Heat weld TPO boot 2" from the the edges, fusing the boot to the TPO membrane roof.

\*Fasteners are not included

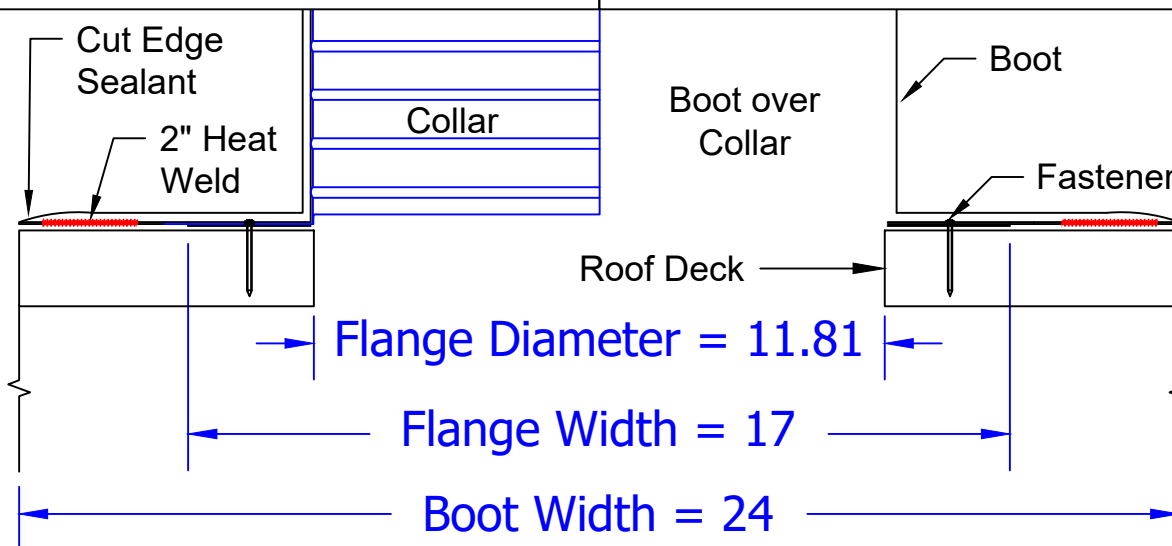

Drawing not to scale